

BODY MIC
(in1p dmic1)

HEADSET MIC
(in2p s.ended)

MODEM OUTPUT
(diff)

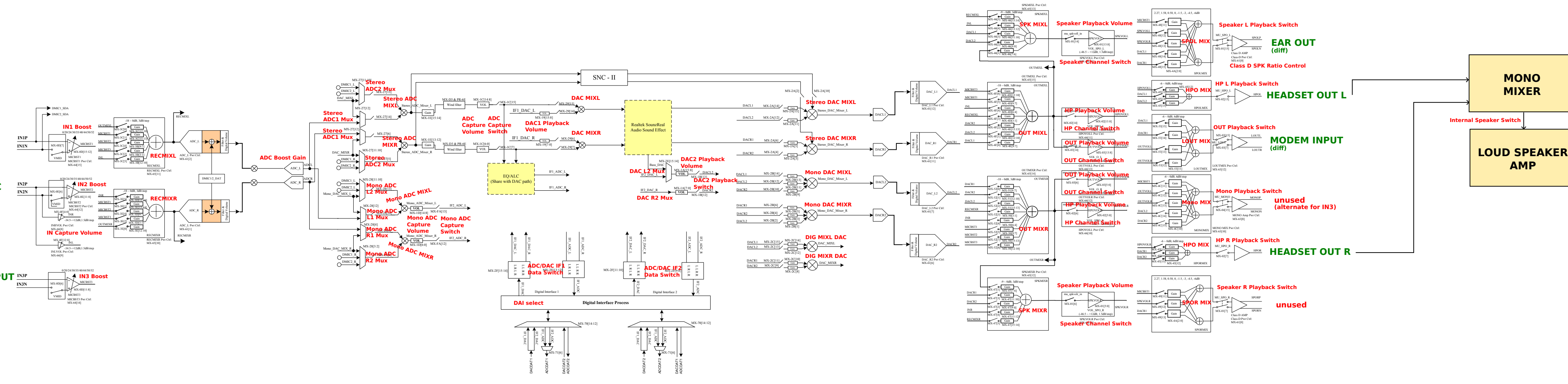

RK3399 I2S0

BT PCM